

4" New Construction Can

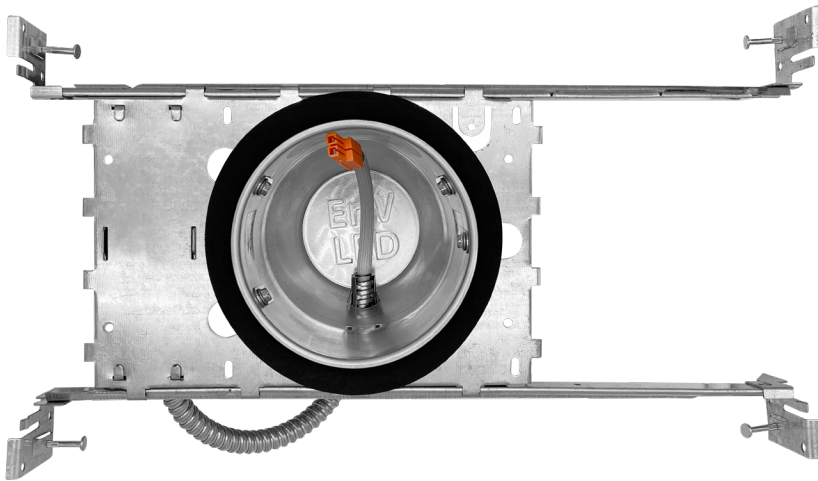
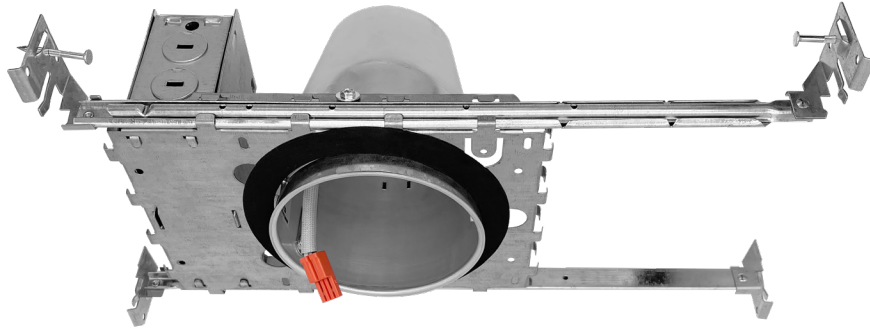

The EnVision LED 4" can is suitable for use with EnVision LED 4" models that are available in various selections. Choose the correct can for your application with our remodel or new construction version. Both cans are IC-rated and have an LED quick connect input.

Housing:

Single wall formed aluminum construction. Openings are gasketed for AIR-TITE installation. 5 1/2" height allows use in 2" x 6" joist construction. AIR-TITE aperture gasket is pre-installed.

Remodel Arm:

Single wall formed aluminum construction. Openings are gasketed for AIR-TITE installation. 5 1/2" height allows use in 2" x 6" joist construction. AIR-TITE aperture gasket is pre-installed.

Mounting:

Four remodel clips secure housing and accommodate 1/2" and 5/8" ceiling material.

Junction Box:

- Six 1/2" trade size conduit knockouts with true pry-out slots
- All leads are #18AWG Wire, the ground wire is connected to the bottom, and quick connectors are supplied on all leads.
- Accepts a wide range of non-metallic sheathed cables
 - The standard cable types used in lighting in both U.S. and Canada.
 - Allows wiring connections to be made outside the junction box.

LED Module Connection:

EnVision's 4" modules simply install with a plug-in 120/277V line voltage wiring connector (UL and CSA Listed Luminaire Disconnect). The LED quick-connect pre the high efficacy rating of the luminaire.

Compliance:

- Use with designated EnVision LED modules for Energy Star qualification.
- Can be used for State of California Title 24 high efficacy compliance with designated LED modules JA8.
- Can be used for International Energy Conservation Code (IECC) high efficacy compliance with designated LED module.

Qualification:

IC and Airtight Can Certified under ASTM-E283 and listed UL/cUL 1598. May be used to meet insulated ceiling* and restricted air-flow requirements such as:

- Washington State Energy Code
 - International Energy Conservation Code (IECC)
 - New York State Energy Conservation Construction Code (NY-ECCC)
 - State of California Title 24 "Recessed Luminaires in Insulated Ceilings."
- * Not to be used in direct contact with spray foam insulation.

UL Labels:

- UL/cUL Listed 1598 Luminaire
- UL/cUL Listed for Damp Location
- UL/cUL Listed for Wet Location, with select trims
- UL/cUL listed for Direct Contact with insulation and combustible material*

C4 - NC - I C A T - L E D

Volt 120/277V	Watt 50W Max
-------------------------	------------------------

Specs and model numbers are subject to change with or without notice

FEATURES

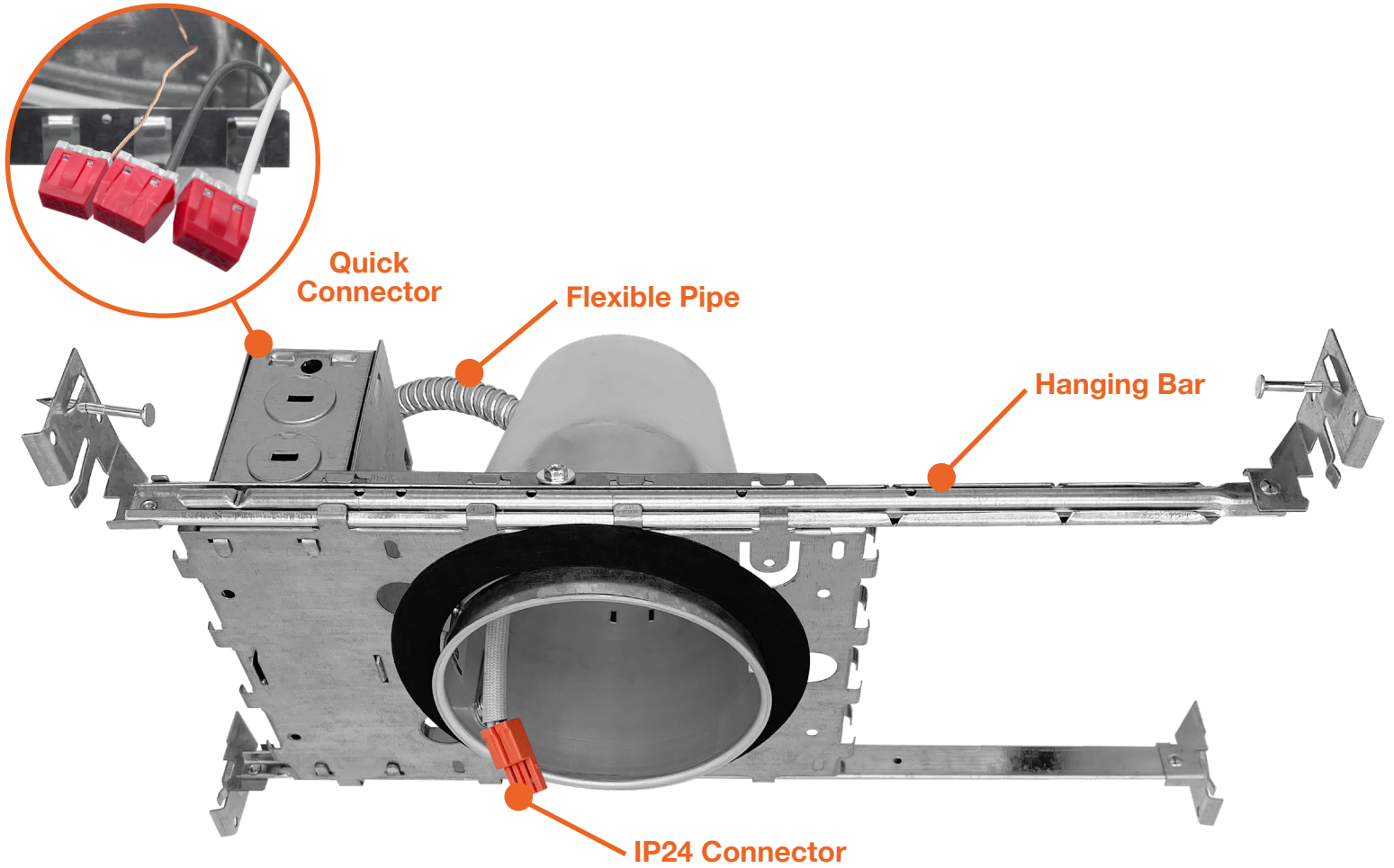

DIMENSIONS

